

REVISION RECORD				
REV	ECD	DESCRIPTION	DRFT	CHKD

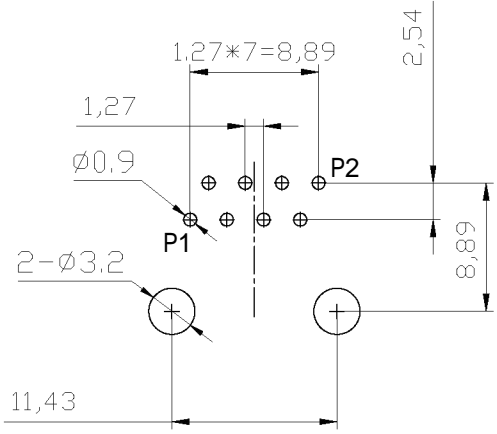
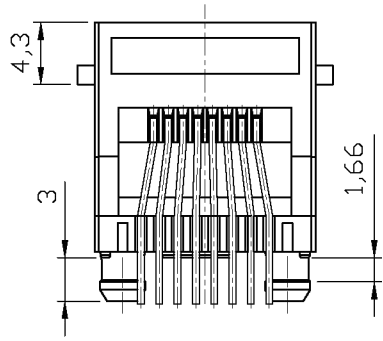
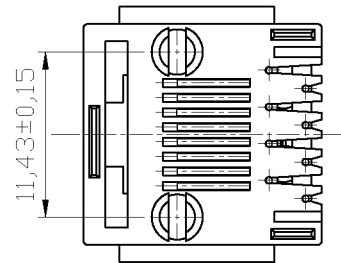
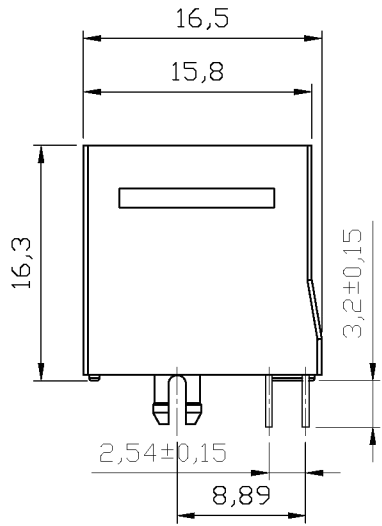
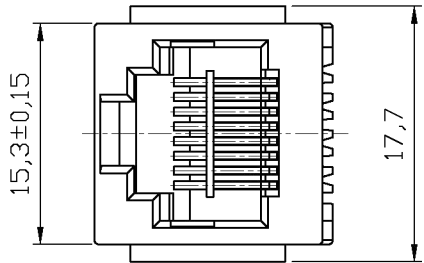

PC Board Layout
Component Side Shown

NOTES:

MATERIAL:

- 1. HOUSING MATERIAL : GLASS FILLED POLYESTER UL94V-0.
- 2. CONTACT MATERIAL : PHOSPHOR BRONZE $\varnothing=0.46\text{mm}$.
- 3. PLATING : GOLD PLATING 3u"~50u" OVER NICKEL

ELECTRICAL:

- 1. VOLTAGE RATING : 125 VAC RMS.
- 2. CURRENT RATING : 1.5 AMP.
- 3. CONTACT RESISTANCE : 30 MILLIOHMS MAX.
- 4. INSULATION RESISTANCE : 500 MEGOHMS MIN @ 500V DC .
- 5. DIELECTRIC WITHSTANDING RESISTANCE : 1000V AC RMS 50Hz. 1MIN.

MECHANICAL:

- 1. DURRABILITY : 750 CYCLES MIN.
- 2. PCB RETENTION PRE-SOLDER : 1 LB MIN.

ENVIRONMENTAL:

- 1. STORAGE : -40° C TO 85° C.
- 2. OPERATION : 0° C TO 70° C.

PART NUMBER:

DETACHED LISTS	MM (INCH)		DFTO: SHB	DATE: 2007.05.0	Coorle 库乐科技 TITLE 5222 TOP ENYRY JACK 8P8C	
	TOLERANCES EXCEPT AS NOTED		CHKD: LANBO	DATE: 5		
			MFO:	DATE:		
			APPVL:	DATE:		
MM		MATERIAL :		QTY :		
.0 ± 0.15	±			DRAWING NO. TE52A1001		
.00 ± 0.075	±			/PART NO.		
.000 ± 0.05	±			SIZE A3		
ANGLES ± 0.5		FINISH :		REV 0		
THIRD ANGLE PROJECTION		SCALE :		DO NOT SCALE DRAWING		
				SHEET DF		